



# MixSwitch

## OWNER'S MANUAL

### NORTH AMERICA (U.S., Canada, Mexico)

Contact Distribution Ltd.  
38 Thornmount Drive, Unit #1  
Scarborough, On M1B 5P2  
Canada

Tel: 416-287-1144  
Fax: 416-287-1204

E-mail: [info@contactdistribution.com](mailto:info@contactdistribution.com)  
[service@contactdistribution.com](mailto:service@contactdistribution.com)

### EUROPE AND UK

Pro Audio-Technik  
Technologiezentrum Herzbachtal  
Zum Wartturm 15  
D-63571 Gelnhausen  
Germany

Tel: +49 (0) 6051 - 914029  
Fax: +49 (0) 6051 - 914059

E-mail: [info@proaudio-technik.de](mailto:info@proaudio-technik.de)  
[info@apb-dynasonics.com](mailto:info@apb-dynasonics.com)

## **IMPORTANT SAFETY INSTRUCTIONS**

### **CAUTION:**

**PLEASE READ AND OBSERVE ALL WARNINGS AND INSTRUCTIONS IN THIS INSTALLATION AND**

**OPERATING GUIDE AND THOSE MARKED ON THE UNIT. RETAIN THIS GUIDE FOR FUTURE REFERENCE.**

This unit has been designed and manufactured to assure personal safety. Improper use can result in electric shock or fire hazard. The safeguards incorporated in this unit will protect you if you observe the following procedures for installation, use, and servicing. This unit does not contain any parts that can be repaired by the user.

### **DO NOT REMOVE ANY COVERS OR SUB-ASSEMBLIES, OR YOU MAY BE EXPOSED TO DANGEROUS VOLTAGES. REFER SERVICING TO QUALIFIED SERVICE PERSONNEL ONLY.**

- Read these instructions. – All of these safety and operating instructions should be read before this product is operated
- Keep these Instructions. – The safety, operating and use instructions should be retained for further reference.
- Heed all warnings. – All warnings on the product and in the operating instructions should be adhered to.
- Follow all instructions. – All operating and use instructions should be followed.
- Do not defeat the safety purpose of the polarized or grounding-type plug. A polarized plug has two blades with one wider than the other. A grounding type plug has two blades and a third grounding prong. The wide blade or the third prong is provided for your safety. If the prong does not fit into your outlet, consult an electrician of the obsolete outlet.
- Do not use this apparatus near or water. – Do not expose apparatus to dripping or splashing and ensure that no objects filled with liquids, such as vases, glasses or cups are placed on this apparatus. Do not operate on or near wet surfaces such as swimming pools and do not expose to rain.
- Clean only with dry cloth. – Unplug the product from the wall outlet before cleaning. Do not use liquid cleaners.
- Do not block ventilation openings. Install in accordance with manufacturers instructions. – Slots and openings in the assembly are provided for ventilation, to ensure reliable operation of the product, and to protect from overheating. Care should be taken never to block these openings in any operating situation.
- Do not install near any heat source such as radiators, heat registers, stoves, or other apparatus that produce heat.
- Protect the power cord from being walked upon or pinched, particularly at the plugs, convenience receptacles, and the point where they exit from the unit.
- Only use attachments/accessories specified by the manufacturer.
- Use only the cart, stand, tripod, bracket, or table specified by the manufacturer, or sold with the apparatus. When a cart is used, use caution when moving the cart/apparatus combination to avoid injury from tip-over.
- Unplug this apparatus during lightning storms or when unused for long period of times.
- Refer all servicing to qualified service personnel. Service is required when the apparatus has been damaged in any way, such as power-supply cord or plug damaged, liquid has been spilled or objects have fallen into the apparatus, the apparatus has been exposed to rain or moisture, does not operate normally, or has been dropped.
- To completely disconnect mains power from this apparatus, the power supply cord must be unplugged.
- Check AC power source for correct voltage and sufficient current capacity.
- Unplug the unit from AC mains before moving, servicing, or cleaning.
- Do not use frayed or damaged power cords or connectors.
- Do not place the unit on an unstable surface.
- Do not operate and immediately unplug equipment from AC mains if liquid has entered the unit.
- Do not plug unit into AC mains if it has physically been damaged in any way.
- Secure and protect ALL cabling to and from the units to prevent they being walled on, pinched, or pulled.
- Do not install the unit in areas of high electromagnetic or RF fields.
- Observe proper procedures for lifting and moving this unit as its weight and size requires that more than a single person be employed in these operations.
- Should the unit be damaged in any way or contaminated with liquid, have the unit inspected and serviced by qualified service personnel.
- This unit contains no user serviceable parts. All servicing must be performed by a qualified service engineer or through APB-DynaSonics or its qualified dealer.
- Operate in accordance with U.S. Governments' Occupational and Health Administration (OSHA) requirements, specifications, suggestions and regulations or those of any other local governing requirements where the equipment is to be used or serviced.

## **YOUR MIXSWITCH CONSOLE SWITCHING DEVICE**

Welcome to the APB-DynaSonics family. Please take a moment to review this manual. It will ensure a better understanding of the operation of this mixer and may open up new possibilities into how you use this product.

This manual will appear within our web site [www.apb-dynasonics.com](http://www.apb-dynasonics.com) with the latest updates as well as new supplemental information. We suggest that you occasionally check our web site for additional information about your mixer as well as for new product releases and news from APB-DynaSonics. Should you have any questions or comments about this or any other APB product, please do not hesitate to contact us at:

For North America:  
Tel: 416-287-1144  
Fax: 416-287-1204

E-mail: [info@contactdistribution.com](mailto:info@contactdistribution.com)  
[service@contactdistribution.com](mailto:service@contactdistribution.com)

For Europe or the UK:  
Tel: +49 (0) 6051 - 914029  
Fax: +49 (0) 6051 - 914059

E-mail: [info@proaudio-technik.de](mailto:info@proaudio-technik.de)  
[info@apb-dynasonics.com](mailto:info@apb-dynasonics.com)

### **Manual Scope**

This manual is not intended to teach you how to mix or how to set up a complete sound system. Should you be looking for such information, May we suggest that you do a search for "Pro Audio Books" on the internet, or attend one of the many fine Recording Schools that may be available to you. Many of these schools offer courses in Live Performance associated subjects as well as basic mixing techniques.

One of the best sources of teaching the technical aspect of system design and operation is through the Syn-Aud-Con organization:

Synergetic Audio Concepts, Inc., 8780 Rufing Road Greenville, IN, 47124 – USA  
Tel: 800-796-2831 Fax : 812-923-3610 For calls outside of the US: 812.923.0174  
Email: [bbrown@synaudcon.com](mailto:bbrown@synaudcon.com)  
[www.synaudcon.com](http://www.synaudcon.com)

# INDEX

## Overview

FRONT PANELS .....	6
REAR PANELS .....	7
BLOCK DIAGRAM .....	8-9
FUNCTIONAL DESCRIPTION .....	10-11

## A & B Main Inputs

LEVEL MONITORING & LISTENING .....	12
REAR PANEL CONNECTORS .....	13

## Auxiliary Sources

ANNOUNCE MIC .....	14-15
STEREO PROGRAM INPUT .....	16-17
STEREO LINE INPUT .....	18-19
AUXILIARY SOURCES – REAR CONNECTORS .....	20

## Remote and Expansion Control

REMOTE CONTROL OF MASTER .....	21
EXPANDER CONTROL .....	21

## General Info

XX .....	XX
DIMENSIONS & MOUNTING .....	XX
INTERCONNECTING .....	XX
XX .....	XX
SPECIFICATIONS .....	XX

## Front Panel Overview

### Master Front Panel



### Expander Front Panel

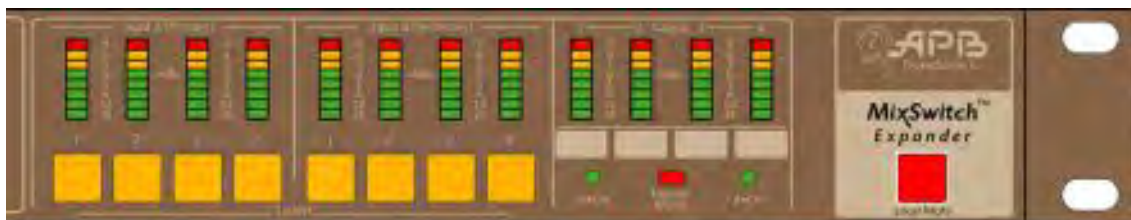
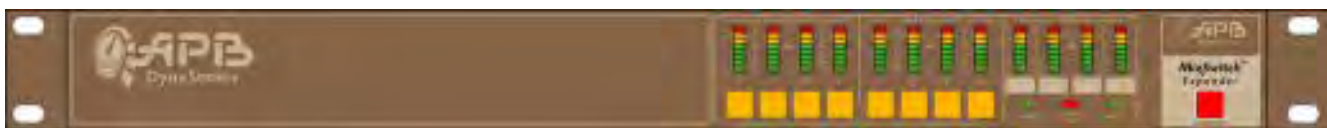

## Rear Panel Overview

### Master Rear Panel



### Expander Rear Panel





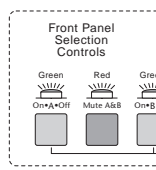
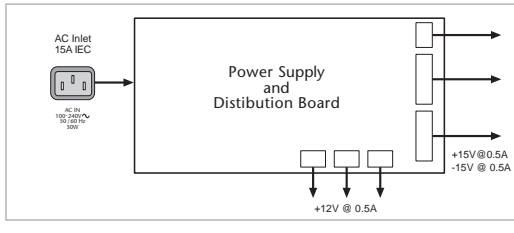
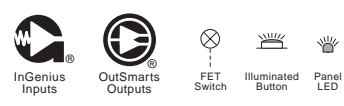
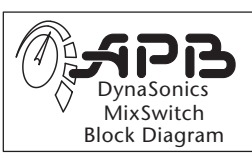
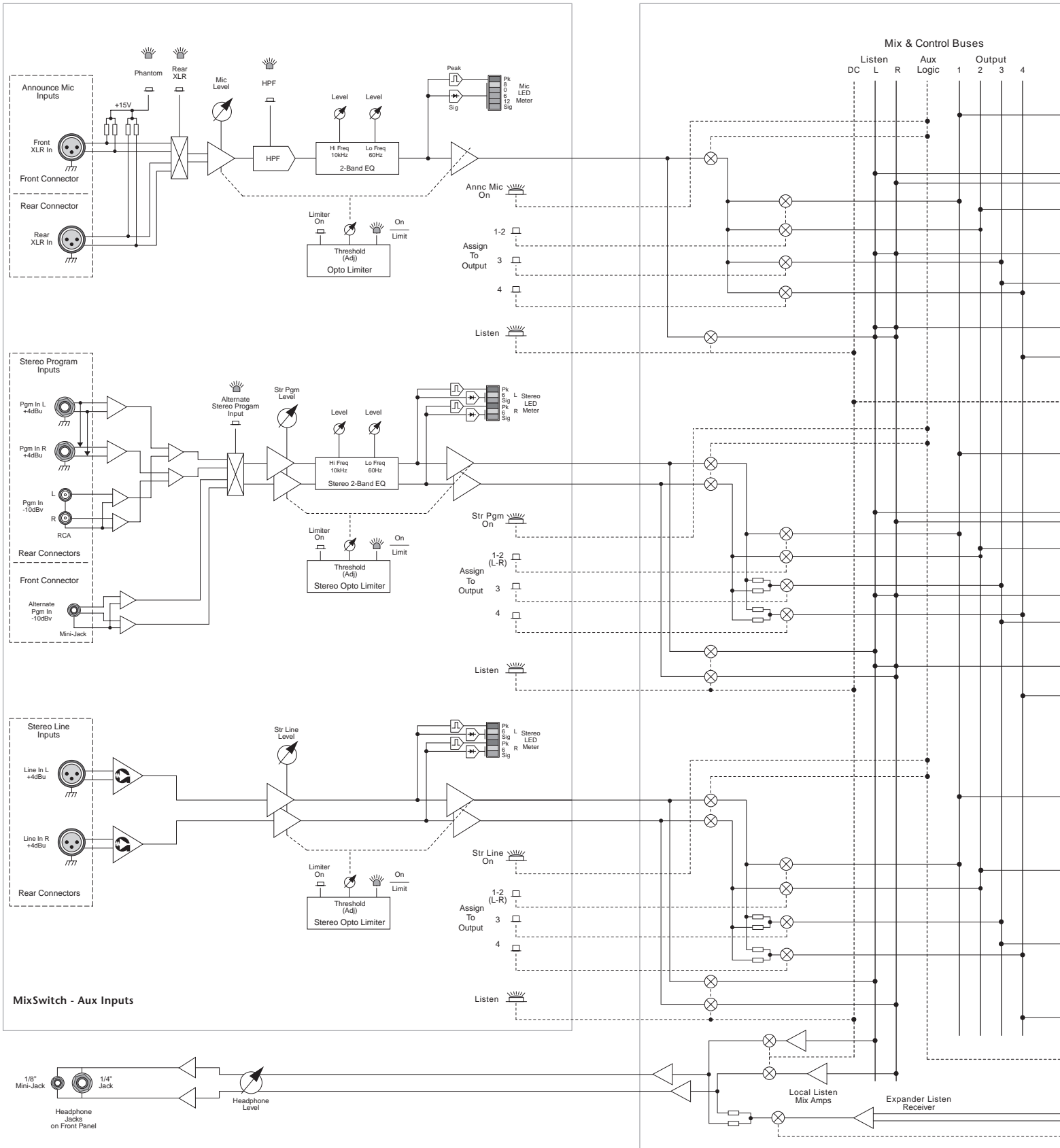

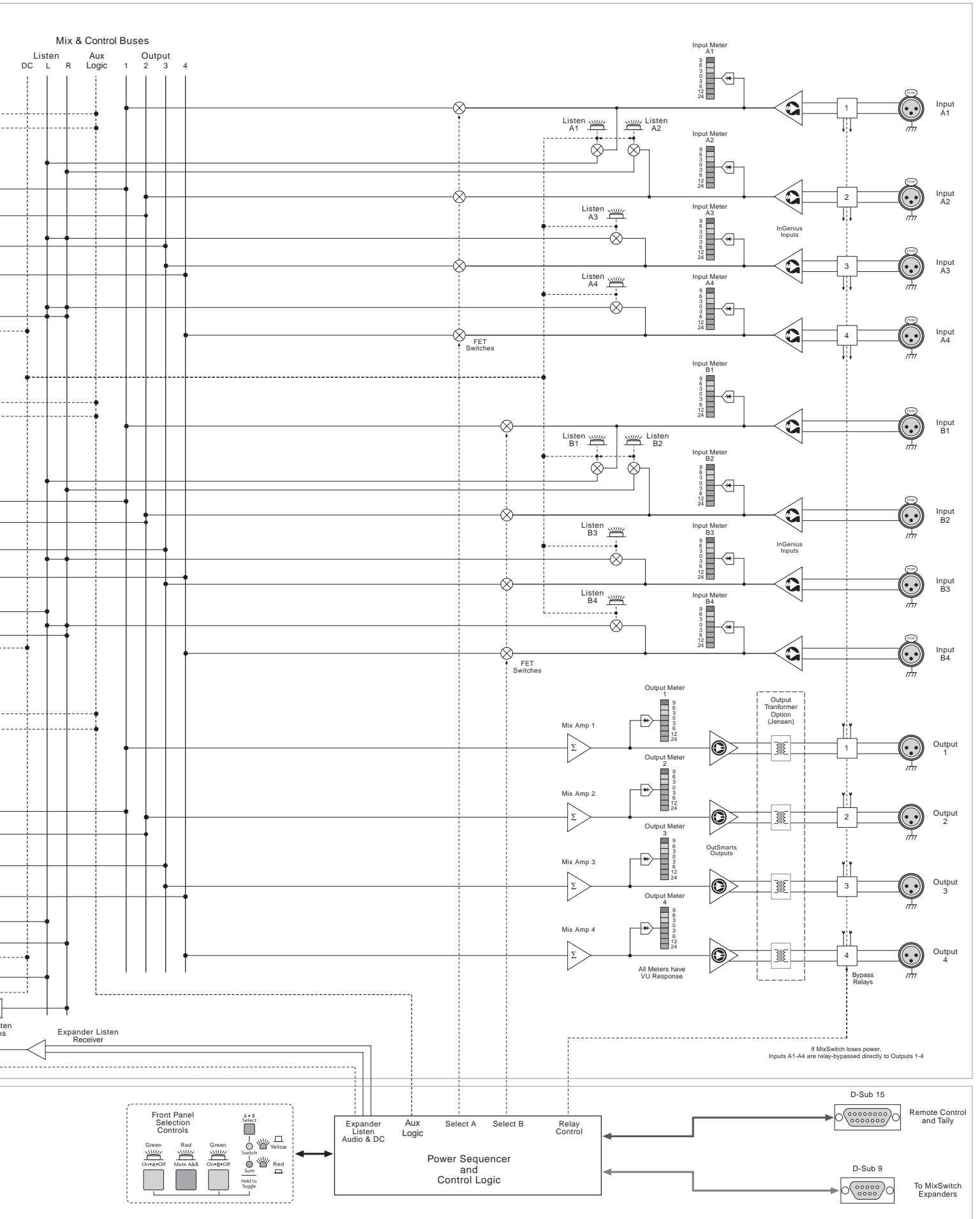



## MixSwitch - Functional Description

MixSwitch can be thought of as a high-quality, 4-channel A-B Switch. Four "A" Inputs and four "B" Inputs are either switched or combined into four Outputs. A1 is switched or combined into Output-1, A2 into Output-2, A3 into Output-3, and A4 into Output-4. Inputs B1 through B4 are likewise steered to Output-1 through Output-4.

A front-panel mode-switch determines whether the A and B Inputs are selected individually (Switch) or mixed together (Sum). 2 LEDs indicate the desired Mode. A separate toggle/select switch is provided for the A and B Inputs plus an additional switch to Mute both sources.

**NOTE: When unpowered, the MixSwitch will hard-bypass the A-Inputs to their respective Outputs via internal relays. When bypassed, no internal circuitry is connected to the XLR jacks except for these relays (i.e. True-bypass mode).**

Inputs are routed to their respective Outputs at Unity Gain. When A and B are both selected, they are mixed together equally, both at unity gain. The gain-staging of the MixSwitch provides the headroom needed for this function.

Although the main function of the MixSwitch is basically simple, we had to insure that it was as transparent to the audio signals as possible. To this end, we've used the latest and greatest interface chips available from THAT Corp to make connecting to the outside world as trouble-free as possible. The InGenius® input stage can easily deal with the inconsistencies of real-world balanced sources. The OutSmarts® outputs are capable of driving long lines without distortion or instability.

Here is a simplified block diagram of the basic A-B switching function.

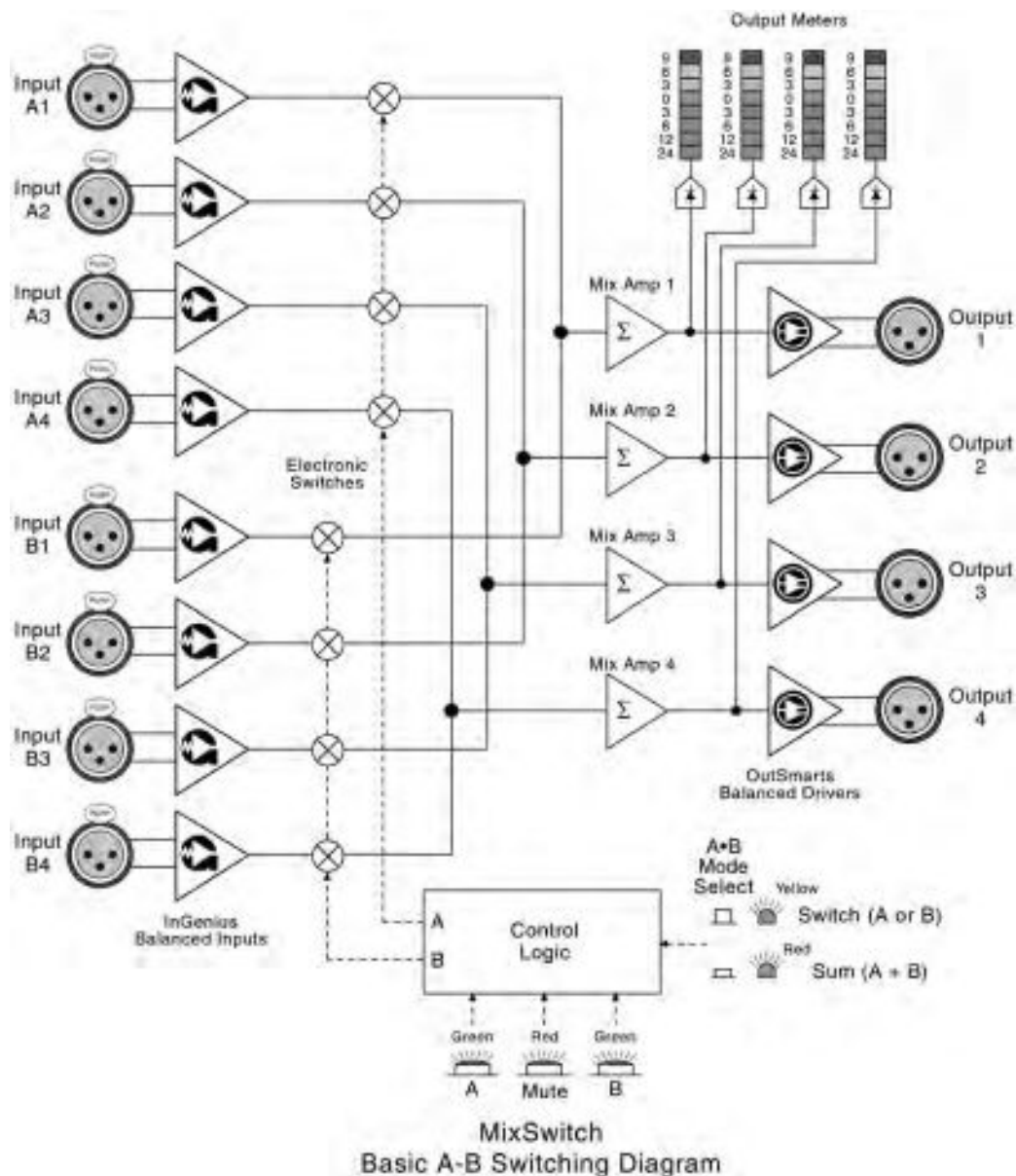

## MixSwitch - Functional Description

### Basic Features

The main switching function of the MixSwitch is controlled by 2 switches, with 2 additional switches providing Mode & Muting control.

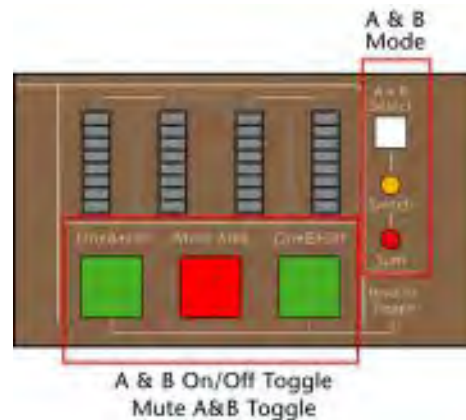

The A & B On/Off toggle switches are soft-latching and they typically change state with each push. Depending on the Mode switch, the A & B switches will also interact. To avoid mistaken presses, there is a slight delay before the A or B switch will toggle; hold the button down for approx 1/2 sec to change state. An internal jumper allows you to change this to a quicker response. In the descriptions below, when “Press” is mentioned, note that you have to really “Press and Hold” to account for this delay since that is the normal preset (factory default). If the jumper has been changed, then “Press” is all that’s needed and the indicated operation will occur without delay.

#### A & B Alternate Operation:

When the A & B Mode switch is set to “Switch” (white button up, Yellow LED illuminated), the MixSwitch will allow only a single set of Inputs, either A or B, to be routed to the Outputs. The A & B buttons interact while in this Mode. Pressing A repeatedly will toggle the state of A between On and Off. If B is pressed when A is On, B will become active and A will turn Off. Pressing A when in this state will then turn A back on and turn B off.

Note: Even though the A & B switches interact, the individual switches will still toggle state if pressed. You can turn off both sets of Inputs and have nothing routed to the Outputs.

#### A & B Additive Operation:

When the A & B Mode switch is set to “Sum” (white button down, Red LED illuminated), the MixSwitch will allow both sets of Inputs to be routed to the Outputs. The A & B buttons do not interact while in this Mode.

Pressing A or B will toggle their state between On and Off.

Note: Since the individual switches always toggle state when pressed, you can turn off both sets of Inputs and have nothing routed to the Outputs.

This Mode is useful to combine the outputs of 2 consoles (up to 4 of the Outputs from each console) to create a “bigger” console; each set of Input signals is summed at unity. If more than 4 Outputs need to be combined (Auxes or Subgroups from 2 consoles), then additional MixSwitch Expanders can be connected to and controlled by the MixSwitch Master.

**Note: The connection from the Master to the Expander(s) is via a supplied DSub-9 cable. ONLY control signals are sent from the Master, the individual audio Ins & Outs remain isolated to each MixSwitch. More about this when the Expander is described.**

#### Mute A & B:

This illuminated button allows you to mute the A & B inputs to the Outputs. It does not affect any of the Auxiliary sources, ONLY A & B are Muted. The Mute button is also a soft-toggle like A & B, but has its own delay setting. By default it is set for No Delay; pressing the Mute switch will immediately change its state. There is an internal jumper that will apply a short delay to the operation of this switch.

**Note:** Even though A & B will both be muted, their individual buttons retain their current state and illumination. This allows you to know which set of Input(s) will turn back on once the Mute is released.

**Note:** The On/Off state of all 3 of these soft-latching switches will normally be remembered and restored if the MixSwitch temporarily loses power. An internal jumper allows the restore function to set only the “A” input On, Clear ALL soft-latching switches, or restore the state of ALL soft-latching switches. See the Auxiliary Sources for additional info.

## Main Inputs: Level Monitoring & Listening

Each of the 8 Input sources has its own 8-segment LED meter. These meters have an averaging (VU-like) response. The meters show the signal level at the Input XLR. 0VU on the meter (highest green LED) represents +4dBu. The Input meters always show the Input level, the particular Input set, A or B, does not have to be turned On via the A & B On/Off switches for these meters to function.

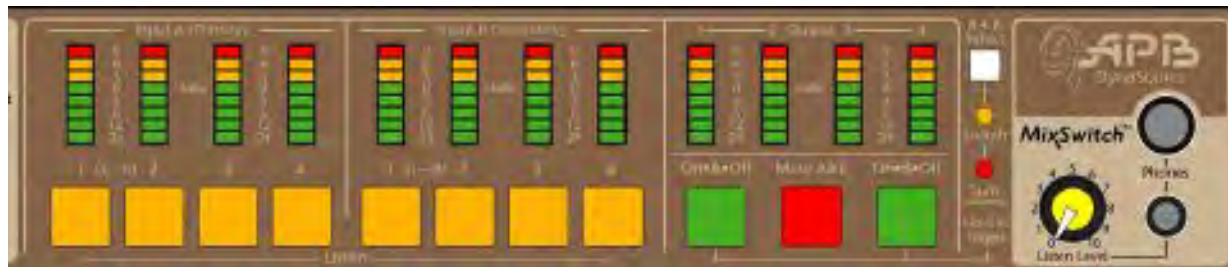

### Listening:

In addition to the metering, a Listen button is also provided for each of the 8 inputs. This allows the operator to listen to each source to ensure that things are fine before enabling that source to the Output.

The Listen button is a mechanically-latching, illuminated switch. The Listen system is additive; any Inputs selected will be mixed together and fed to the headphone circuit. Normally, these Input sources are presented to the headphones as a mono signal (equal level in each ear), but here's where the L-R notation from the Rear panel comes into play.

#### For the 1 & 2 inputs of each Input Set A & B:

If a single Listen button is depressed (1 OR 2), that source is heard in mono. If both the 1 and 2 buttons are depressed, those two signals are split to the phones and Input-1 is heard on the Left and Input-2 is heard on the Right.

This allows you to listen to a stereo source in stereo if it's being fed to the MixSwitch on Input pair A1-A2 or Input pair B1-B2. If not a stereo source, just listen to each input separately and it will appear in mono.

The Listen system can also be fed from the Aux Sources; the 2 stereo sources will be heard in stereo, the mono source in mono.

The Listen Level rotary control adjusts the volume to both the 1/4" and 1/8" headphone jacks.

**NOTE: If any MixSwitch Expanders are connected to the Master, their selected Solo Listen audio will be fed to the Master's Listen System and will be combined with any selected signals in the Master. This allows the operator to monitor the additional Inputs being fed to the Expanders.**

## Main Outputs: Level Monitoring

Each of the 4 Outputs has its own 8-segment LED meter. These meters have an averaging (VU-like) response. The meters represent the signal level at the Output XLR. 0VU on the meter (highest green LED) represents +4dBu. The Output meter only shows the level of that particular Output when there is a signal present. These signals can come from the Main Inputs (A or B) or any of the Aux Sources if they have been assigned to that particular Output.

## Main Inputs: Rear Panel Connectors

There are two sets of 4 input jacks: Inputs A1 through A4 and Inputs B1 through B4.  
The jacks are Latching, 3-Pin Female XLR.  
Pin-2 is in-polarity, Pin-3 is out-of-polarity, Pin-1 is connected directly to the chassis metalwork.  
Electronically Balanced Input with InGenius® balanced receiver ICs from THAT Corp.  
Maximum Input Level: +24dBu  
Input Impedance: >20K $\Omega$  (Differential)

Inputs are labeled 1 through 4, but 1 also indicates (L), and 2 also indicates (R). This L-R labeling is for convenience only, these signals can come from any source.



## Main Outputs: Rear Panel Connectors

There is one set of 4 output jacks: Outputs 1-4  
The jacks are Latching, 3-Pin Male XLR.  
Pin-2 driven +, Pin-3 driven -, Pin-1 is connected directly to the chassis metalwork.  
Electronically Balanced Output with OutSmarts® balanced driver ICs from THAT Corp.  
Maximum Output Level: +28dBu into 600  $\Omega$  or higher  
Output Impedance: 50 $\Omega$

Outputs are labeled 1 through 4, but 1 also indicates (L), and 2 also indicates (R). This L-R labeling is for convenience only, these signals can go to any destination.



### NOTE:

Jensen output transformers can be factory-fitted to the 4 outputs at time of order (not field-installable).  
Contact APB for details.

**NOTE: When unpowered, the MixSwitch will hard-bypass the A-Inputs to their respective Outputs via internal relays. When bypassed, no internal circuitry is connected to the XLR jacks except for these relays (i.e. True-bypass mode). When the MixSwitch is hard-bypassed, the transformers (if installed) are also bypassed and not in the audio path.**

## MixSwitch - Auxiliary Sources

In addition to the main A & B Inputs, the MixSwitch has 3 supplementary audio inputs.

- 1) Announce Mic
- 2) Stereo Program In
- 3) Stereo Line In

These 3 inputs are called the Auxiliary Sources. These signals can be routed to any of the 4 outputs total independent of the Main A & B Inputs. These Aux Sources add important functionality to the audio system being driven by the MixSwitch.

### Announce Mic

#### Front Panel Controls and Input

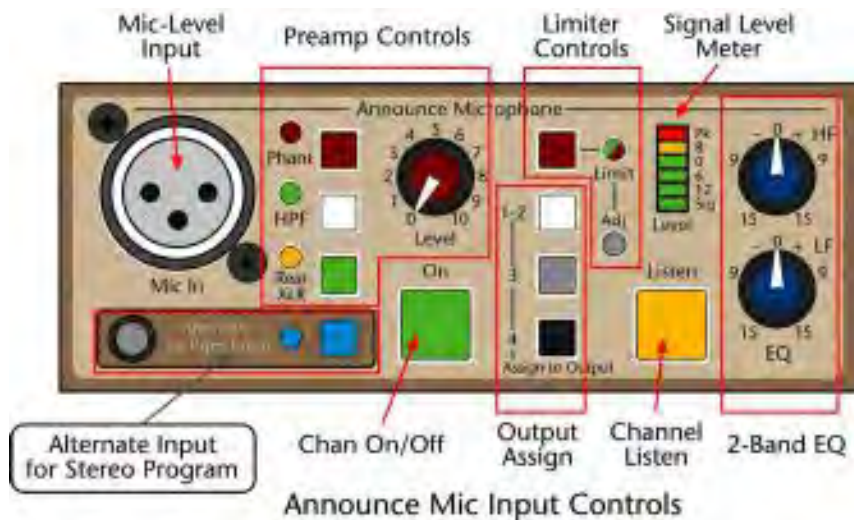

This section accepts a microphone-level signal (Front & Rear XLR jacks are provided). This Input can be used to make announcements before, during or after a show. This feature allows you to make these announcements even if the main Console has not been set up (or has already been packed-up). Since this input is independent of the A & B Main-Audio selection, during a festival situation, where the Consoles are being constantly switched, this Mic can always feed the PA independent of which Console is selected.

#### **Preamp Controls:**

**XLR Input:** Default is the front-panel jack, the Green button is used to select the Rear-panel XLR

**Phant switch:** Red button (w/Red LED) applies +15V to Pins 2 & 3 of the XLR jacks (both front & rear)

**HPF switch:** White button (w/Green LED) enables a 75Hz Hi-Pass filter (-12dB/Oct)

**Rear XLR switch:** Green button (w/Yel LED) selects the Rear-panel XLR jack instead of the Front-panel XLR

**Level Control:** Adjusts the overall 2-stage gain of the circuit. More detail later

#### **Limiter Controls:**

Pressing the Red button will enable the Limiter circuit. The Limit LED will turn Green to show it's enabled, Red when active.

When disabled (Red button UP), the limiter is out of the circuit (and the LED is not illuminated).

The threshold can be adjusted through the hole in the panel with a small, flat-blade screwdriver. Adjustment range is approx -10dBu to +18dBu (CCW to CW). The Limit LED will turn RED to show over-threshold limiting action. The limiter is designed mainly for protection and will hard-limit with a ratio >20:1 over most of its range.



## MixSwitch - Auxiliary Sources

### Announce Mic

#### Front Panel Controls and Input

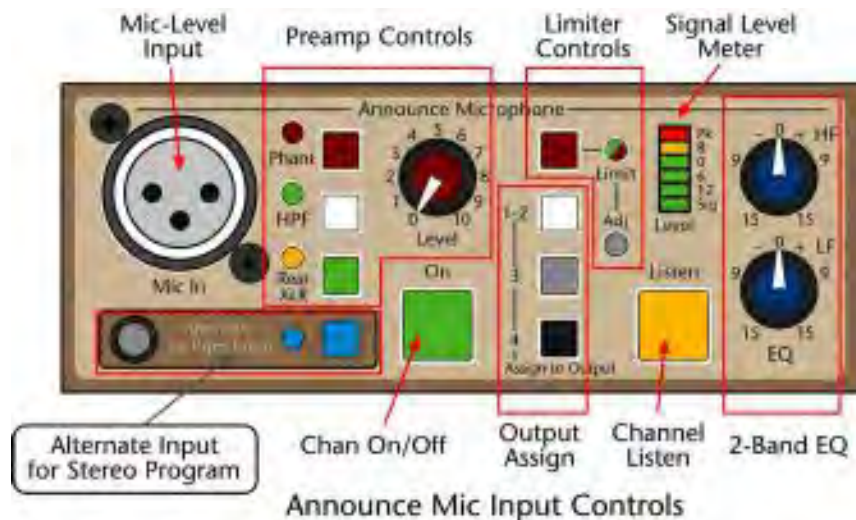

#### **Chan On/Off:**

This Green On/Off toggle switch is soft-latching and will change state with each push: On is illuminated, Off is non-illuminated

When On, the Announce Mic signal will feed any assigned Outputs.

**Note:** The On/Off state this soft-latching switch will normally be remembered and restored if the MixSwitch temporarily loses power. An internal jumper allows the restore function to set only the "A" input On, Clear ALL soft-latching switches, or restore the state of ALL soft-latching switches.

#### **Output Assign:**

Each button assigns the Announce Mic to the specified Output(s). Since the source is mono, it is always fed equally to each selected Output.

NOTE: Output assign is AFTER the Chan On/Off switch. The switch must be On (illuminated) for the signal to get to the Outputs.

#### **Signal Meter:**

This 6-segment, averaging meter shows the output level of the Announce Mic circuit. Metering is always active and is independent of the Chan On/Off control. It reflects what you will hear with the Channel Listen button.

#### **2-band EQ:**

High & Low Shelving EQ is provided. Corner freqs of 8kHz and 80Hz

#### **Channel Listen:**

The Listen button is a mechanically-latching, illuminated switch. The Annc Mic post-level/post-EQ signal is fed to the Listen System in mono. The Listen function is independent of the Chan On/Off switch.

#### **Level Control :**

More about this control: Unlike a typical console, there is no separate gain trim control and channel level fader. The Level control combines both functions into one; it controls both the front-end gain and the 2<sup>nd</sup> stage feeding the selected Outputs. The EQ circuitry is located between these 2 stages, the Chan Listen and metering is located after the 2<sup>nd</sup> stage.



## MixSwitch - Auxiliary Sources

### Stereo Program Input

#### Front Panel Controls and Input

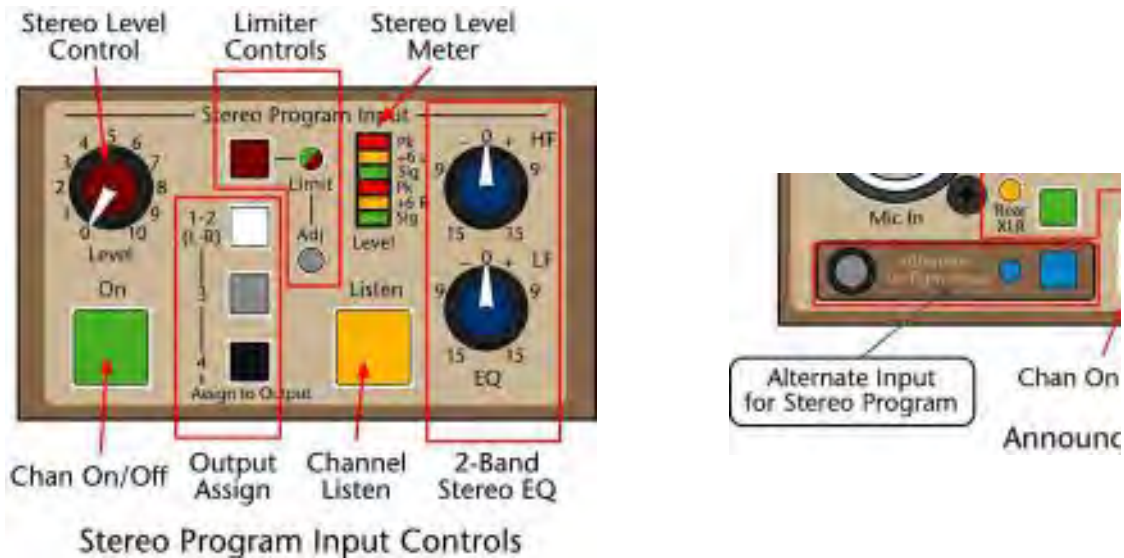

This section accepts a Line-level signal from Rear-panel TRS and RCA jacks; both input sources are active and will be combined into a single stereo source if both sets of jacks are used. This Input can be used to provide music before, during or after a show. This feature allows you to provide music even if the main Console has not been set up (or has already been packed-up). Since this input is independent of the A & B Main-Audio selection, during a festival situation, where the Consoles are being constantly switched, this music can always feed the PA independent of which Console is selected.

#### **Alternate Input:** (located near the Announce Mic controls)

This 1/8" Stereo mini-jack can also be used for signal input. Pressing the Blue button (w/Blue LED) will select this front-panel jack instead of the default rear-panel jacks. Suitable for portable music players and similar sources.

#### **Level Control:**

Adjusts the overall 2-stage gain of the circuit. This operates in a similar manner to the Announce Mic circuit described earlier. The limiter circuit operates before the first stage, the EQ circuitry is located between the 2 stages, and the 2<sup>nd</sup> stage feeds the Outputs.

#### **Limiter Controls:**

Pressing the Red button will enable the Limiter circuit. The Limit LED will turn Green to show it's enabled, Red when active.

When disabled (Red button UP), the limiter is out of the circuit (and the LED is not illuminated).

The threshold can be adjusted through the hole in the panel with a small, flat-blade screwdriver. Adjustment range is approx -10dBu to +18dBu (CCW to CW). The Limit LED will turn RED to show over-threshold limiting action. The limiter is designed mainly for protection and will hard-limit with a ratio >20:1 over most of its range.

## MixSwitch - Auxiliary Sources

### Stereo Program Input

#### Front Panel Controls

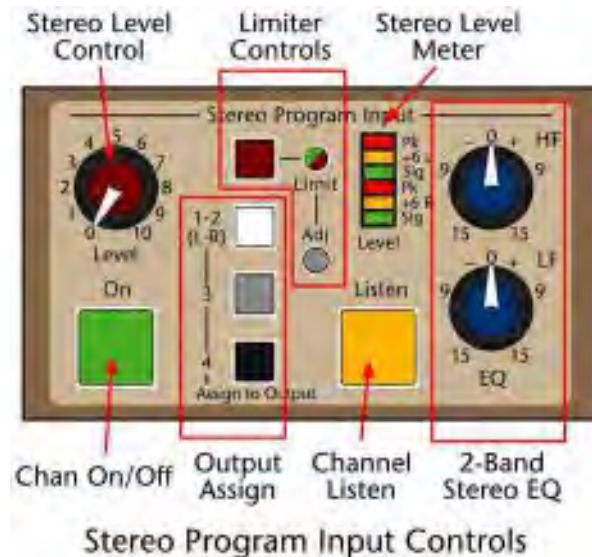

#### **Chan On/Off:**

This Green On/Off toggle switch is soft-latching and will change state with each push:

On is illuminated, Off is non-illuminated

When On, the Stereo Program signal will feed any assigned Outputs.

**Note:** The On/Off state this soft-latching switch will normally be remembered and restored if the MixSwitch temporarily loses power. An internal jumper allows the restore function to set only the "A" input On, Clear ALL soft-latching switches, or restore the state of ALL soft-latching switches.

#### **Output Assign:**

Each button assigns the Stereo Program to the specified Output(s).

When 1-2 is selected, the Left source feeds Output-1, Right feeds Output-2.

For 3 and 4, a summed-mono mix is fed to the selected Output.

NOTE: Output assign is AFTER the Chan On/Off switch. The switch must be On (illuminated) for the signal to get to the Outputs.

#### **Signal Meter:**

This dual, 3-segment, averaging meter shows the output level of the Stereo Pgm. The top 3 LEDs display the Left-side activity, the lower 3 LEDs show the Right-side.

Metering is always active and is independent of the Chan On/Off control. It reflects what you will hear with the Channel Listen button.

#### **2-band Stereo EQ:**

High & Low Shelving Stereo EQ is provided. Corner freqs of 8kHz and 80Hz

#### **Channel Listen:**

The Listen button is a mechanically-latching, illuminated switch. The Stereo Program post-level/post-EQ signal is fed to the Listen System in stereo. The Listen function is independent of the Chan On/Off switch.

## MixSwitch - Auxiliary Sources

### Stereo Line Input

#### Front Panel Controls

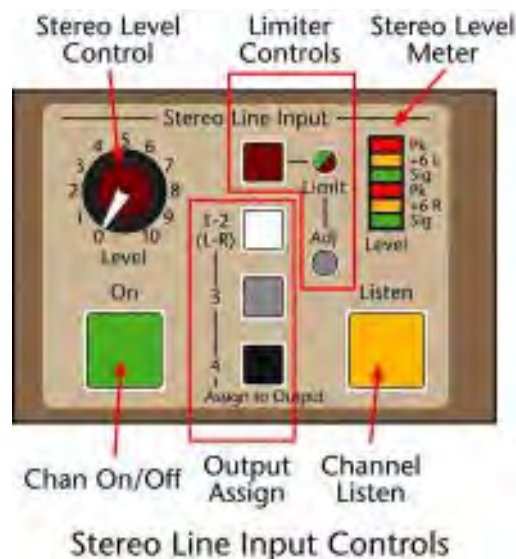

This section is similar to the Stereo Program Input, but lacks the EQ. Input source is a Line-level signal from Rear-panel XLR jacks; these balanced inputs are fitted with InGenius balanced Receivers. This Input can be used to feed an additional console into the system or any additional line-level signals needed for the show.

#### **Level Control:**

Adjusts the overall 2-stage gain of the circuit. This operates in a similar manner to the Stereo Program circuit described earlier. The limiter circuit operates before the first stage; the 2<sup>nd</sup> stage feeds the Outputs.

#### **Limiter Controls:**

Pressing the Red button will enable the Limiter circuit. The Limit LED will turn Green to show it's enabled, Red when active.

When disabled (Red button UP), the limiter is out of the circuit (and the LED is not illuminated).

The threshold can be adjusted through the hole in the panel with a small, flat-blade screwdriver. Adjustment range is approx -10dBu to +18dBu (CCW to CW). The Limit LED will turn RED to show over-threshold limiting action. The limiter is designed mainly for protection and will hard-limit with a ratio >20:1 over most of its range.

## MixSwitch - Auxiliary Sources

### Stereo Line Input

#### Front Panel Controls

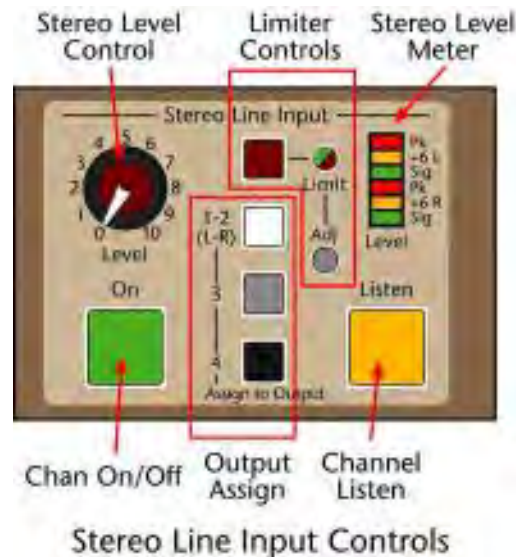

#### **Chan On/Off:**

This Green On/Off toggle switch is soft-latching and will change state with each push:

On is illuminated, Off is non-illuminated

When On, the Stereo Line signal will feed any assigned Outputs.

**Note:** The On/Off state this soft-latching switch will normally be remembered and restored if the MixSwitch temporarily loses power. An internal jumper allows the restore function to set only the "A" input On, Clear ALL soft-latching switches, or restore the state of ALL soft-latching switches.

#### **Output Assign:**

Each button assigns the Stereo Line to the specified Output(s).

When 1-2 is selected, the Left source feeds Output-1, Right feeds Output-2.

For 3 and 4, a summed-mono mix is fed to the selected Output.

NOTE: Output assign is AFTER the Chan On/Off switch. The switch must be On (illuminated) for the signal to get to the Outputs.

#### **Signal Meter:**

This dual, 3-segment, averaging meter shows the output level of the Stereo Pgm. This dual, 3-segment, averaging meter shows the output level of the Stereo Pgm. The top 3 LEDs display the Left-side activity, the lower 3 LEDs show the Right-side. Metering is always active and is independent of the Chan On/Off control. It reflects what you will hear with the Channel Listen button.

#### **Channel Listen:**

The Listen button is a mechanically-latching, illuminated switch. The Stereo Program post-level/post-EQ signal is fed to the Listen System in stereo. The Listen function is independent of the Chan On/Off switch.

## MixSwitch - Auxiliary Sources - Rear Connectors



### Aux Inputs:

The input jacks for all 3 Aux Sources are located on the rear panel of the MixSwitch.

## Remote Connectors (DSub-15 and DSub-9):

The MixSwitch Master is fitted with 2 DSub connectors for Remote operation and Expander-control.

The DSub-15 allows the MixSwitch Master to be remotely operated; all of the 6 soft-latching switches can be remotely toggled. Tally lines allow the operator to monitor the status of each switch.

All Input-toggle lines are Active-Low; momentarily connect to 0-Volts to toggle switch state.

All Tally lines are Active-Low; Tied to 0-Volts when active.

DSub-15 connections: MixSwitch fitted with DSub-15 Female Connector

Pin#	Function
1:	0-Volts (Internally tied to Chassis with 10Ω resistor)
2:	Toggle Master Mute (Momentarily connect to 0-Volts to change state of Master Mute switch)
3:	Toggle A-Select (Momentarily connect to 0-Volts to change state of A-Select switch)
4:	Toggle B-Select (Momentarily connect to 0-Volts to change state of B-Select switch)
5:	Toggle Ann Mic Sw (Momentarily connect to 0-Volts to change state of Annc Mic switch)
6:	Toggle Stereo Pgm Sw (Momentarily connect to 0-Volts to change state of Str Pgm switch)
7:	Toggle Stereo Line Sw (Momentarily connect to 0-Volts to change state of Str Line switch)
8:	+5 volts Can be used for Tally LED power, current limited to 30mA
9:	0-Volts (Internally tied to Chassis with 10Ω resistor)
10:	Tally Master Mute (Open-collector w/10K pullup to +5V; tied to 0-Volts when Mute is ON)
11:	Tally A-Select (Open-collector w/10K pullup to +5V; tied to 0-Volts when A-Select is ON)
12:	Tally B-Select (Open-collector w/10K pullup to +5V; tied to 0-Volts when B-Select is ON)
13:	Tally Annc Mic (Open-collector w/10K pullup to +5V; tied to 0-Volts when Annc Mic is ON)
14:	Tally Stereo Pgm (Open-collector w/10K pullup to +5V; tied to 0-Volts when Stereo Pgm is ON)
15:	Tally Stereo Line (Open-collector w/10K pullup to +5V; tied to 0-Volts when Stereo Line is ON)

The DSub-9 connector allows the MixSwitch Master to control any added MixSwitch Expanders or MixSwitch-C units. Both of these units are fitted with In & Out DSub-9 connectors (Male & Female) to allow this control function to daisy-chain to additional units when connected.

DSub-9 connections: MixSwitch fitted with DSub-9 Female Connector

Pin#	Function
1:	0-Volts (Internally tied to Chassis with 10Ω resistor)
2:	Solo Audio – (Balanced signal for Listen Audio)
3:	Solo DC Control
4:	Select A (Tied to 0-Volts when active)
5:	Mute Command (Tied to 0-Volts when active)
6:	Solo Audio + (Balanced signal for Listen Audio)
7:	0-Volts (Internally tied to Chassis with 10Ω resistor)
8:	Power OK (Tied to 0-Volts when active)
9:	Select B (Tied to 0-Volts when active)



## TECHNICAL SPECIFICATIONS

<b>General Specifications</b>	
<b>Frequency Response (A or B Input to Output)</b>	+0/-0.1dB 5Hz to 50kHz (ref to 1kHz)
<b>THD + Noise (A or B Input to Output)</b>	<0.005% @ +15dBu output 20Hz to 20kHz
<b>Phase Response (A or B Input to Output)</b>	+2/-2 degrees 20Hz to 20kHz (ref to 1kHz)
<b>Noise</b>	
<b>Output Noise- No Inputs Selected</b>	<-95dBu
<b>Output Noise- A or B Input Selected</b>	-90dBu (Inputs terminated with 600Ω)
<b>Crosstalk (measured at 1KHz, +15dBu Out)</b>	
<b>Main Mute</b>	>100dB
<b>A to B Isolation</b>	>90dB
<b>Aux Source Isolation (Chan Off)</b>	>90dB
<b>Input / Output Impedance</b>	
<b>A, B, Stereo Line Input (InGenius) (XLR)</b>	>20KΩ Balanced
<b>Stereo Program Input (TRS)</b>	10KΩ Balanced
<b>Stereo Program Input (RCA)</b>	5KΩ Unbalanced
<b>Announce Mic Input (XLR)</b>	2KΩ Balanced
<b>Main Outputs (OutSmarts)</b>	50Ω Symmetrically-Balanced (To Feed 600Ω or greater)
<b>Input / Output Levels</b>	
<b>A or B (InGenius) Balanced Inputs</b>	+24dBu Max Input Level
<b>XLR (OutSmarts) Balanced Outs</b>	+28dBu Max Output into 600Ω or greater